

Literature Review on Weight Optimization of the Knife Valve by using Finite Element Analysis and Experimental Stress Analysis

Mr. Ashish Mule
Research Scholar

Department of Mechanical Engineering
Dr.J.J.Magdum College of Engineering, Jaysingpur

Mr. Y. R Patil

Associate Professor

Department of Mechanical Engineering
Dr.J.J.Magdum College of Engineering, Jaysingpur

Abstract

A valve is device that regulates, directs or controls the flow of fluid by opening, closing or partially obstructing various passage ways. Knife valve is a type of a gate valve. These types of valves are commonly used in pulp industries, pharmaceutical industries, where these valves handle slurry type fluids. The advantage of this type valve is easy operation and maintenance. In the world of advanced technology and globalization the organization are moving towards the optimization using advanced technique. The objective of the paper is to identify the various methods of design and optimization of Knife Valve. Using finite element analysis find the stress distribution over the valve for different position will be found out. For Experimental verification Use of strain gauges will be done to find the stress and deformation generated in the actual valve body.

Keywords: valve, knife valve, optimization, finite element analysis

I. INTRODUCTION

In the world of advanced technology and globalization the organization are moving towards the optimization using advanced technique. A valve is device that regulates, directs or controls the flow of fluid by opening, closing or partially obstructing various passage ways they are used in various applications like industrial (oil, gas, power generation, mining chemical manufacturing),military, commercial, residential. Valves are various types having wide range of size and applications the valves are classified on operation of the valve and fluid handled. The basic use of valve is to regulate the flow, stop the flow and avoid the non-returning of the fluid. The valves are designed using the previous experience and on codes defined by various institutions.

Valves are found in virtually every industrial process, including water and sewage processing, mining, power generation, processing of oil, gas and petroleum, food manufacturing, chemical and plastic manufacturing and many other fields.

The main parts of the most usual type of valve are the body and the bonnet. These two parts form the casing that holds the fluid going through the valve.

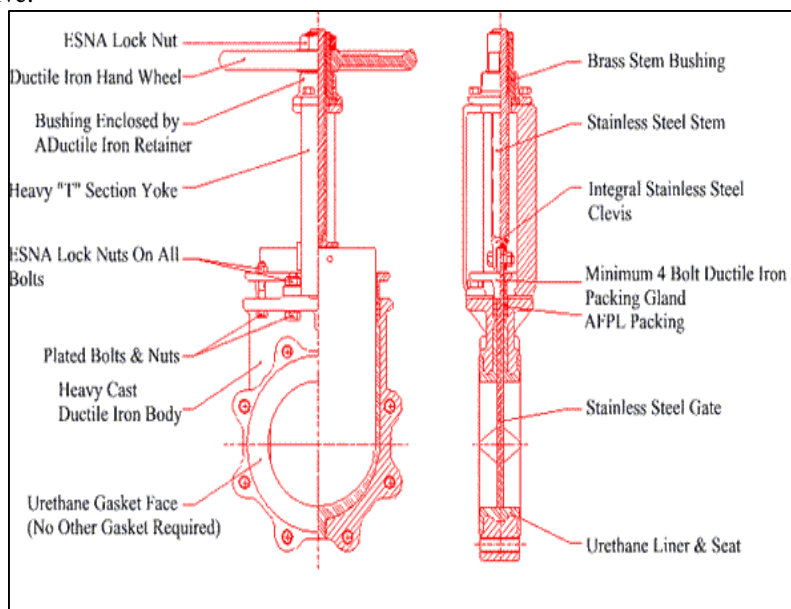

Fig. 1: sectional view of the knife valve

A. Operation of the valve:

Knife valve is a type of a gate valve. These types of valves are commonly used in pulp industries, pharmaceutical industries, where these valves handle slurry type fluids. The advantage of this type valve is easy operation and maintenance. The gate plate used in Knife valve, as shown in above figure, has a shape similar to knife. The stem is attached to the knife gate and yoke sleeve. The stem has a screw threading and yoke sleeve as a tapping done on it. Hand wheel is mounted on the stem.

As the hand wheel is rotated the stem moves up and down. As stem is connected to the gate rotary motion is transferred to linear motion of the plate. The valve gets shut off when plate comes down. Seal ring is generally provided to avoid leakage after shut off.

II. LITERATURE REVIEW

The design of the valve were previously done using the past design or on the conventional procedures. The development of advanced technique like finite element analysis the use of such techniques was done for optimizing the designs of the valve bodies. Some the research work discussed below.

X G Song [1] in his paper Analysis and optimization of a butterfly valve disc disused about the conventional design prouder for butterfly valve. The valve used for chemical industries. The CAD model was created for a butterfly valve. Use of CAE commercial software was done for finding the stresses induced on the valve. By using design of experiments the optimum valve of the variables in design were finalized.

Dr. K.H. Jatkar and Sunil S. Dhanwe [2] have worked on classical theory and finite element analysis of the gate valve. Finite element analysis carried out by using Ansys software. Stress value of classical and finite element analysis compared and it matches approximately with each other and that can be used for further development of the gate valve.

Ron Darby [3] in this study a model for the opening lift dynamic response of a pressure relief valve in gas/vapor service is presented which accounts for all of these effects through a set of five coupled nonlinear algebraic/differential equations. These equations are solved by a numerical method that can be implemented on a spreadsheet to predict the position of the valve disk as a function of time for given valve characteristics, operating conditions, and installation parameters. The model incorporates the influence of the various parameters on the stable/unstable nature of the disk response.

THOMAS GERNAY [4] in his study explained the use of finite element analysis in optimizing the lock gate valve used waterway. The design was done considering the standards. The finite element model was built for the existing design. The modification was done in existing design and the modified design was tested in finite element analysis software. The results showed acceptable optimization in the lock gates.

Shridhar Gurav (et.al) [5] carried out Weight Optimisation Of 12"-600 Gate Valve By Using Finite Element Analysis And Experimental Stress Analysis. The paper gives the brief look on the suitability of gate valve weight reduction by using finite element analysis and compare with experimental stress analysis with matching principal stress one and two and von mises stress theoretical and actual. and according to that weight reduction of valve body using constrains of valve body pressure and stress.

Sonali Mantati and A. N. Surde [6] performed analysis gate valve. The analysis was done for different positions: when the valve is in fully closed condition, when valve is partially opened or closed condition, and when valve is in fully opened condition. Analysis to be done to find out the stresses and deformation developed.

III. CONCLUSION

From the literature review it can be seen that inventors have worked hard on developing various methodologies for designing the valves. The analysis of knife gate valve was not observed in the literature reviewed till now. The literature review confirms that use of finite element analysis can be help for the optimization of the design.

REFERENCES

- [1] X G Song, et.al, "Analysis and optimization of a butterfly valve disc", Journal of Process Mechanical Engineering Volume E, 2009 223: 81, 2009,PP-81-89
- [2] Dr. K.H. Jatkar, Sunil S. Dhanwe, "Finite Element Analysis of Gate Valve", International Journal of Engineering and Innovative Technology (IJEIT) Volume 2, ISSN: 2277-3754 ISO 9001:2008 Certified, Issue 10, April 2013,PP-277-281
- [3] Mr. THOMAS GERNAY, "Optimization and analysis of lock gates in the framework of the "Seine-Escaut-Est" waterway upgrading, PP 01-20.
- [4] Mr.Shridhar S.Gurav, Dr. S. A. Patil, "Weight Optimisation Of 12"-600 Gate Valve By Using Finite Element Analysis And Experimental Stress Analysis"- A Review", International Journal of Engineering And Science Vol.4, Issue 9 (Sept 2014), Issn (e): 2278-4721, Issn (p):2319-6483,PP 31-32..
- [5] Sonali Mantati, A. N. Surde, "Finite Element Analysis of Flexible Wedge Type (2"#150) Gate Valve", International Journal of Emerging Technology and Advanced Engineering,ISSN 2250-2459, ISO 9001:2008 Certified Journal, Volume 5, Issue 6, June 2015, PP 194-198
- [6] Prof. Laukik B. Raut., Pradnyawant .K.Parase, "Weight Reduction of 12"-150 Class Plug valve Casting Body by Finite Element Analysis and Experimental Method", American Journal of Engineering Research (AJER) e-ISSN: 2320-0847 p-ISSN : 2320-0936 Volume-4, Issue-4, pp-108-116