

Reducing the Motor Derating and Torque Pulsation of Induction Motor using Matrix Converter

Rashmi Bhokre

M. Tech Student

*Department of Electrical Engineering
 WCOEM, Nagpur, MS, India*

Surbhi Shrivastava

Assistant Professor

*Department of Electrical Engineering
 WCOEM, Nagpur, MS, India*

Abstract

The output voltages of the variable voltage and variable frequency voltage sources employing voltage source inverter is non-sinusoidal. The output current of a variable frequency current source using current source inverter is also non sinusoidal. When the induction motor is fed by using these inverters odd harmonics will be present in the input supply, because of these inverters output voltage is non-sinusoidal. This harmonics do not contribute the output power of the motor, they produce additional losses in the machine. This harmonic loss reduces the efficiency and cause derating of the motor. These limitations can be overcome by using matrix converter because of its unique feature is pure sinusoidal as output. The matrix converter is superior to inverter drives because of its regeneration ability and four-quadrant operation. Therefore it meets the stringent energy efficiency and power quality.

Keywords: Non-sinusoidal supply, Matrix Converter, Induction Motor, Simulation, Harmonics, Mat lab/Simulink

I. INTRODUCTION

The diode rectifier front – end of the PWM inverters fed harmonics to the utility grid and pollutes the AC line such that other equipment on the same line experience interference and have operating problems such as common failure, Electro Magnetic Interference. Furthermore they have no regeneration capability and in most applications with frequent regeneration operating mode, the regenerated energy is dissipated in a resistive circuit with limited capacity.

The serious drawback of PWM inverters is that the output voltage is non-sinusoidal. The operation of an induction motor with non-sinusoidal supply causes significant reduction in motor efficiency and motor derating. A non-sinusoidal [7] waveform resolved into fundamental and harmonic components using Fourier analysis is, because of the

$$I_s = \sum_{n=1}^{\infty} a_n \sin n\omega t + \sum_{n=1}^{\infty} b_n \cos n\omega t \quad (1)$$

Half wave symmetry [7] as in (1). Where,

$$a_n = \frac{1}{\pi} \int_0^{2\pi} I_s \sin n\omega t d(\omega t)$$

$$b_n = \frac{1}{\pi} \int_0^{2\pi} I_s \cos n\omega t d(\omega t)$$

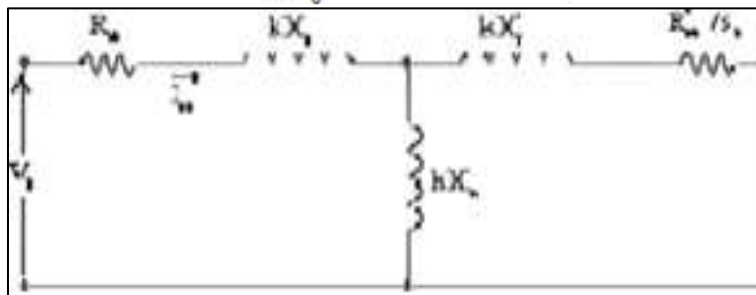

Fig. 1: harmonic equivalent circuit of induction motor

The rms value of nth harmonic in the source current is found by using (1) and (2). The phase displacement of the n^{th} harmonic given in (3), because of the half wave symmetry only odd harmonics will be present such as positive 5th, negative 7th and zero sequence harmonics[7]. While harmonics do not contribute to the output power of the motor.

$$I_n = \frac{1}{\sqrt{2}} [a_n^2 + b_n^2]^{-1/2} \quad (2)$$

They certainly produce additional losses in the motor. The Kth harmonic equivalent circuit of induction motor [6] shown in Fig.1 and the

$$P_h = \sum_{k=5,7} I_{sk}^2 (R_{sk} + R'_{rk}) \quad (3)$$

Harmonic copper loss is given in (4). Where,

$$I_{sk} \cong \frac{V_k}{k(X_s + X'_r)} \quad (4)$$

Here, k = Harmonic sequence

This harmonic loss reduces efficiency and increase thermal loading. The higher the harmonic content, the greater the reduction in efficiency and the increase in thermal loading even at light loads. The mmf and air- gap flux waves produced by different harmonics [7] including fundamental are not stationary relative to each other. Consequently they produce pulsating harmonics, which have zero average value.

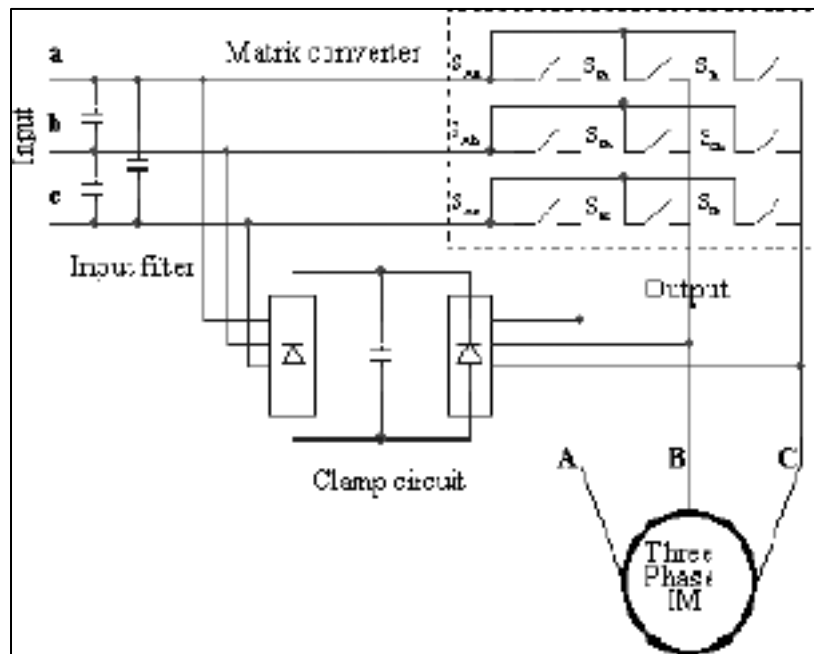

Fig. 2: The practical scheme of matrix converter drive

The negative sequence fifth harmonic air-gap flux wave produces a rotor mmf wave that moves backward at five times the fundamental synchronous speed[6]. The relative speed between the fifth harmonic rotor mmf wave and the fundamental air gap flux wave being six times the fundamental synchronous speed, their interaction produces a pulsating torque at six times the fundamental frequency. The positive sequence seventh harmonic air-gap flux wave produces a rotor mmf wave, which rotates forward at seven times the fundamental synchronous speed. Since the relative speed between the fundamental air-gap flux wave and the seventh harmonic rotor mmf wave is six times the fundamental synchronous speed, their interaction also produces a pulsating torque at six times the fundamental frequency. Similarly the eleventh and thirteenth harmonics produce a torque pulsation twelve times the fundamental frequency, but its amplitude is small. The torque pulsations cause fluctuations in motor speed. When the fundamental frequency is sufficiently large, speed fluctuations are sufficiently low because of the motor inertia. When the fundamental frequency and the motor speed are low, large fluctuations in motor speed are obtained producing a jerky or stepped motion[7]. The amplitude of the torque pulsations depends on the corresponding harmonic voltages and the motor reactance.

The solution for these limitations is achieved by the operation of induction motor by using matrix converter. Because this is the only one AC-AC single stage converter [9] capable to supply pure sinusoidal as input to the induction motor. The trend in power electronics is toward, improving the interaction with the power grid, providing bi-directional power flow, increasing the efficiency of drive while operating at higher switching frequency and decreasing the drive size all of which match the profile of a matrix converter. Compared with other conventional drives there is potential for reduced cost of manufacture and maintenance, and increased power / weight and power / volume ratios. The circuit of the matrix converter is capable to connect the load to the grid directly and inherently bi-directional power flow also offers sinusoidal input current without the harmonics, associated with present in commercial inverters.

II. MATRIX CONVERTER

Matrix Converter (MC) is a new type of direct AC- AC converter[1],[4] which converts input line voltage into variable voltage with unrestricted frequency with-out using an intermediate DC link circuit. MC is an array of controlled semiconductor switches that connects directly the three-phase source to three phase load. A three-phase MC consists of nine bi-directional voltage-blocking switches, arranged in three groups of three each group being associated with an output line. This arrangement of bidirectional switches connects any of the input line a, b or c to any of the output line A, B or C as schematically represented in Fig.2.

In order to provide safe operation of the converter when operating with bi-directional switches two basic rules[10] must be followed. Normally the MC is fed by a voltage source and for this reason, the input terminals should not be short circuited.

Furthermore, the load has typically an inductive nature and for this reason an output phase must never be opened. According to the basic rule, the maximum number of permitted switching states of the MC is reduced to 27. First 6 switching states provide a direct connection of each output line to a different input line producing a rotating voltage vector with same amplitude and same frequency of the input voltage system and direction dependent on the sequence. Another 18 switching states produce active vectors of variable depending on the selected line-to-line voltage but at a stationary position. The last 3 switching states produce a zero vector, by connecting all the output lines to the same input line.

An input filter is necessary to the high frequency ripple from the input current because the matrix converter is capable to connect the load to the grid directly. For protection purposes a clamp circuit is needed to provide safe shut down of the converter during over current on the output side or voltage disturbances on the input side.

A. Bi-directional Switches:

The bi directional switches must be able to block voltage and current in both of its directions[10]. The development of the matrix converter has been obstructed the lack of a forced commutated bi-directional switch. By using unidirectional switches, there are three ways to obtain a bi-directional switch

- 1) The diode embedded unidirectional switch.
- 2) The two Common Emitter (CE) bi-directional switch
- 3) The two Common Collector (CC) bi-directional switches.

The first topology implies higher conduction losses through two FRDs and one IGBT. It has higher switching losses. The other two topologies based on anti-series connection of two unidirectional switches (CE and CC) allow for lower conduction losses through one FRD and one IGBT as shown in Fig 3. This figure shows the different topologies of bi-directional switches. The CC topology is very easy to build the converter in a modular structure as required for high power and this topology is the most favoured combination for low power industrial usage.

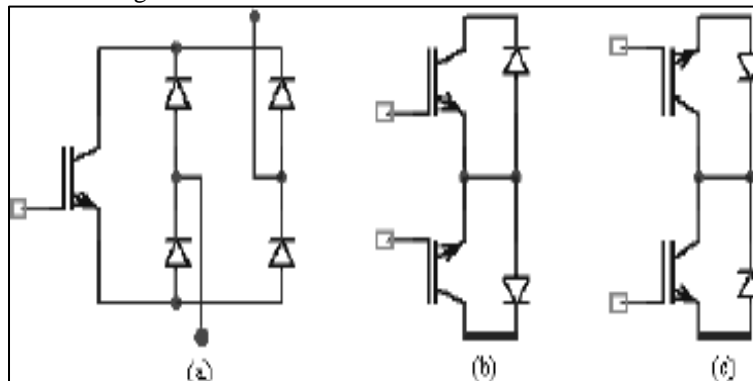

Fig. 3: Bi-directional switch topologies using unidirectional switches: a) diode embedded; b) common emitter(CE); c) common collector(CC).

B. Input Filter

Matrix Converter has the tendency to draw the input from the Grid directly. Because of the matrix converter is connected to the grid, an input filter[1] is necessary to reduce the switching harmonics present in the input current. The requirements for the filter

- 1) To have the cut-off frequency lower than the switching frequency of the converter.
 - 2) To minimize its reactive power at the grid frequency.
 - 3) To minimize the volume and weight for capacitors and chokes (inductors).
 - 4) To minimize the filter inductance voltage drop at rated current (in order to avoid a reduction in the voltage transfer ratio).
- Filter doesn't used to store energy from the load.

C. Clamp Circuit

In matrix converter over voltages can appear from the input side originated by the line or Grid perturbations. Further dangerous over voltages can appear from the output side caused by an over current fault. A clamp circuit[10] is the most common solution to

avoid over voltages coming from the grid and from the motor. The clamp circuit consists of 12 Fast Recovery Diodes (FRD) to connect the capacitor to the input and output terminals.

III. MODULATION TECHNIQUE OF THREE PHASE TO THREE PHASE MATRIX CONVERTER

The Matrix Converter [1] connects any output line to any input line by means of nine bi- directional switches [10]. To consider the modulation problem assume that the switches in the converter are ideal and balanced the input supply.

$$\begin{bmatrix} V_a(t) \\ V_b(t) \\ V_c(t) \end{bmatrix} = V_{im} \begin{bmatrix} \cos(\omega_1 t) \\ \cos(\omega_1 t + 2\pi/3) \\ \cos(\omega_1 t + 4\pi/3) \end{bmatrix} \quad (5)$$

The input voltages are in (5)

The venturini algorithm provides a control of switches [1] like S_{Aa} , S_{Ba} etc. so that the low frequency parts of the synthesized output voltages V_A , V_B and V_C and input currents are purely sinusoidal with the prescribed output frequency, input frequency amplitude and input displacement factor. The switches on each output phase are closed sequentially and respectively. The sequence time T_s is defined as the sum of the switching times in (2)

$$T_s = t_{Aa} + t_{Ab} + t_{Ac} = t_{Ba} + t_{Bb} + t_{Bc} = t_{Ca} + t_{Cb} + t_{Cc} = 1/f_s \quad (6)$$

where, f_s is the switching frequency and is constant t_{Aa} is the on time for switch s_{Aa} . system, the MC input terminals must not be short-circuited and the output terminals must not be opencircuited through bi-directional switches of MC.

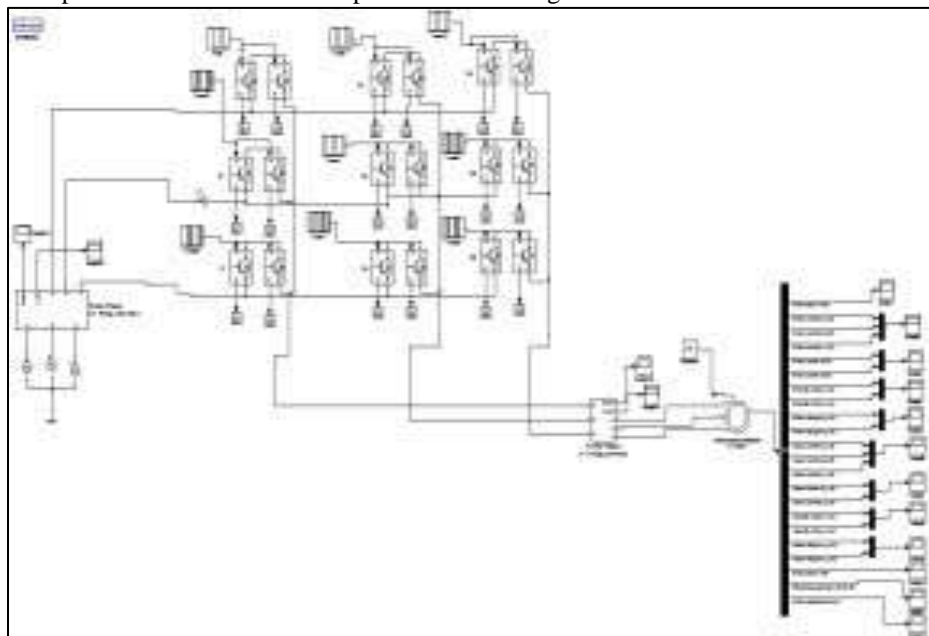

Fig. 4: Matlab Model of matrix converter fed Induction motor drive

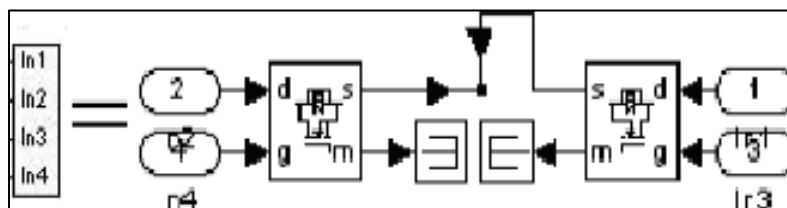

Fig. 5: Subsystem of bi-directional switch

For unity input displacement factor the duty cycle for the switch connected between the input phase β and output phase

$$T_{\beta} = T_s \left[\frac{1}{3} + \frac{2V_o V_{\beta}}{3V_m^2} + \frac{2q}{3\omega_m} \sin(\omega_1 t + \psi_{\beta}) \sin(3\omega_1 t) \right] \quad (6)$$

γ can be defined as, where

$$\psi_{\beta} : 0, 2\pi/3, 4\pi/3$$

corresponding to the input phases a, b and c respectively.

$$V_{\phi} = qV_m \left[\cos(\omega t + \psi_r) - \frac{1}{6} \cos(3\omega t) + \frac{1}{4q_m} \cos(3\omega t) \right] \quad (7)$$

Equations (7) and (8) used for the duty cycle calculation[8], of the switches in the implementation of open-loop control of Matrix Converter fed induction Motor drive[2].

IV. INDUCTION MOTOR

This paper is also describes modeling the induction motor based on the three-phase to three- phase matrix converter output and to investigate the torque pulsating, motor derating and overall efficiency when the induction motor is fed by Matrix Converter. The electromagnetic forces of induction motor equivalent circuit are calculated as the functions of stator and rotor fluxes. This and some other variations of the three-phase model of an induction motor are developed and simulated by authors of this paper. The simulations have been carried out assuming a sampling period of 500us. Simulink induction machine model is also available in the Matlab / simulink –power system block sets and in the literature [3],[5]and [11]. The block diagram of MC fed induction motor and subsystem of BDS is shown in Fig.4 and Fig.5 respectively. The reason for choosing simulink set motor model is it describes both steady state and transient behavior. But in PSPICE software [2] model describes only steady state behavior of the motor

V. SIMULATION RESULTS

The proposed target has been extensively investigated under system circuit level simulations. The system level simulation is made utilizing Matlab/Simulink.

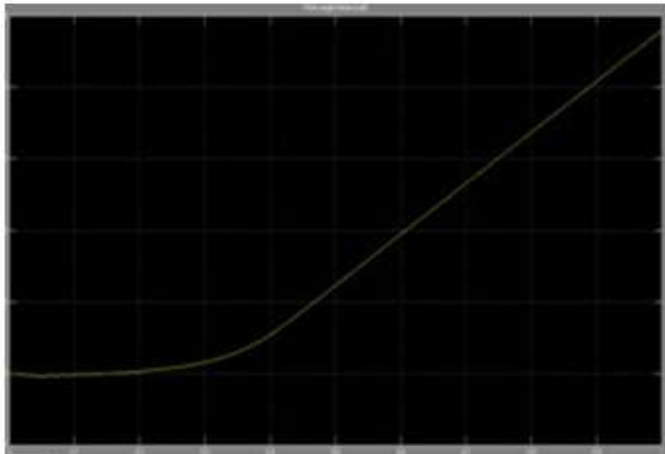

Fig. 6: Rotor Angle (red)

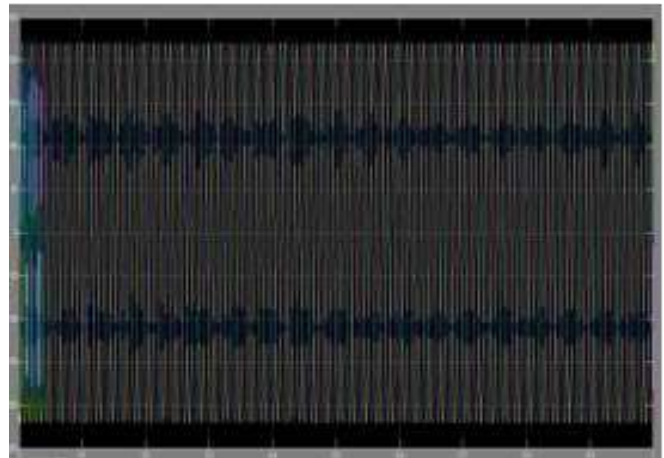

Fig. 7: Simulation result of MC output voltage for vi=220v, fo=50Hz, fs=2kHz

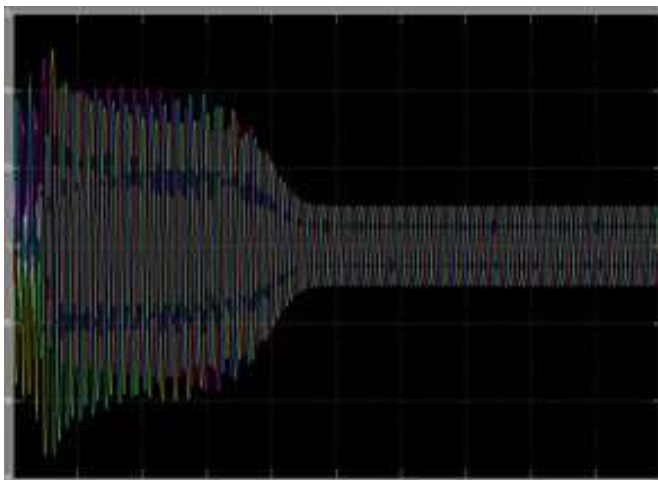

Fig. 8: Output current of three phase to three phase MC for vi=220v,fs=2kHz.

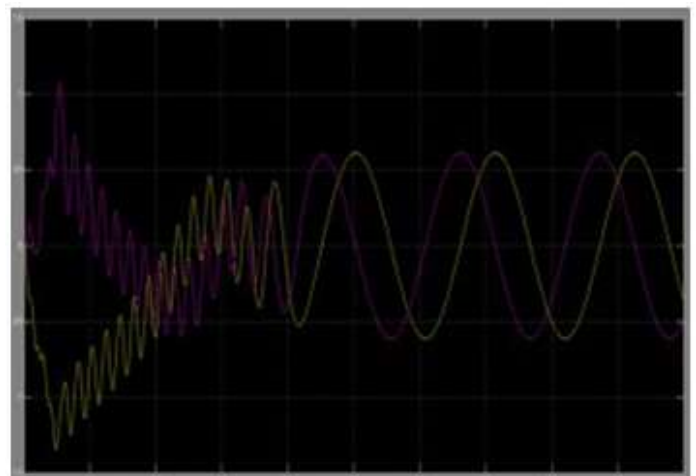

Fig. 9: Rotor Flux Phir-q,d

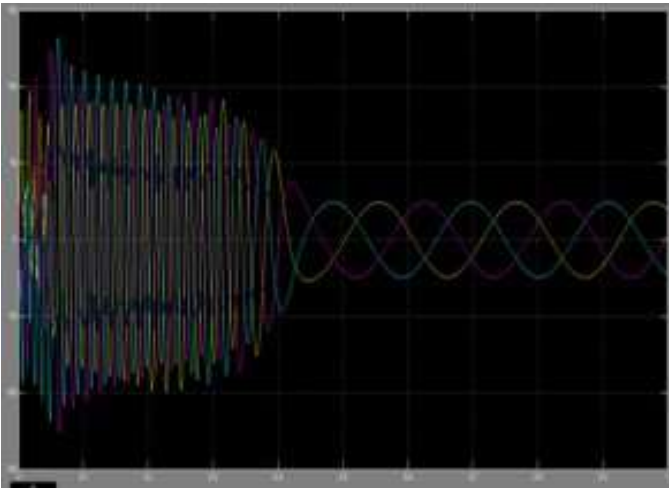

Fig. 10: Rotor current of induction motor fed from MC
fo=50Hz,fs=2kHz.

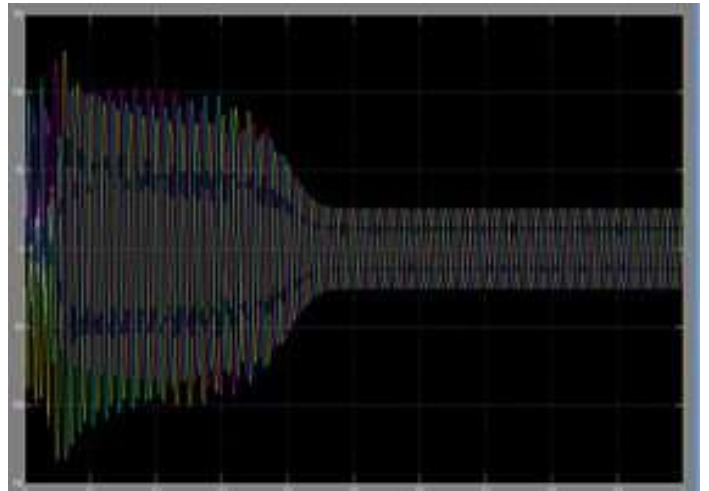

Fig. 11: Stator current of induction motor fed from MC
fo=50Hz,fs=2kHz.

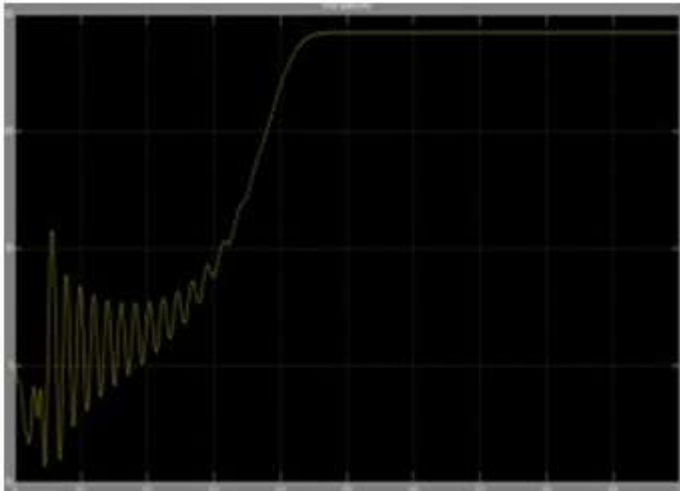

Fig. 12: Speed response of induction motor drive runtime up to
40ms.

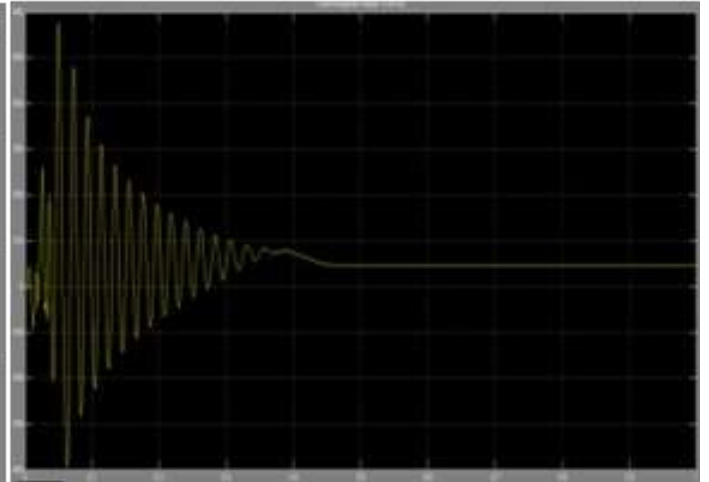

Fig. 13: Output torque of induction motor runtime upto 40ms.



Fig. 14: Stator Flux Pair-q,d

This paper describes only actual outputs of the induction motor fed matrix Converter comparable results with other AC-AC converters. The simulation parameters of induction motor is, Integrator type: ode45.

VI. CONCLUSION

From the simulation results we conclude that the output voltage and input current of Matrix Converter is pure sinusoidal. Now, the induction motor is driven by using Matrix Converter certainly, the torque pulsating, and motor derating is reduced also the efficiency of the induction motor is increased. According to the literature [5] and [11], the induction motor is fed by VSI, CSI sources (non-sinusoidal supplies) the harmonic losses [7] are produced in the machine. They cause significant reduction in motor efficiency and large increase in motor derating, torque pulsating. These limitations can be overcome by using matrix converter because of its unique feature is pure sinusoidal as output. A theoretical investigation was carried out and shown in simulation results. Therefore Matrix Converter is better alternative to the PWM inverters for driving electrical machines.

REFERENCES

- [1] P.W.Wheeler, J.Rodriguez, J.C.Clare and L.Empringham, "Matrix converter –A technology review," IEEE Trans.Ind.Electron. vol.49, no.2, Apr. 2002, pp. 275 - 288.
- [2] Y Tatar and Sedat Sunter, "Pspice modeling and simulation of a matrix converter-fed induction motor drive," Int.J.Eng Springer-Verlag, 2002, pp.295-301.
- [3] D.Casadei, G.Serra and A.Tani, "The use of matrix converters in direct torque of induction machines," IEEE Trans.Ind.Electron. vol.48, no.6, Dec. 2001, pp. 1057 - 1064.
- [4] Sedat Sunter and Tatar Y, "Pspice modeling and design of a snubber circuit for the matrix converter," Int.J.Eng Model 13, 2000, pp.41-46.
- [5] S.Williamson and Catherine L.McClay, "The effect of axial variations in saturation due to skew on induction motor equivalent circuit parameters," IEEE Trans.Ind.Applications, vol. 35, no.6, Nov/Dec. 1999, pp. 1323 – 1330.
- [6] C.L.Neft and C.D.Schauder, "Theory and design of a 30-Hp matrix converter," IEEE Trans.Ind.Applicat., vol.49, no.2, May/June. 1992, pp. 546 - 551.
- [7] G.K.Dubey, Power Semiconductor Controlled Drives, Prentice Hall, New Jersey: 1989, 495.
- [8] M.Imayavaramban, K.Latha and G.Uma, "Analysis of different schemes of matrix converter with maximum voltage conversion ratio," in Proceedings of the 12th IEEE –MELECON, 2004.
- [9] J.W.Kolar and M.Baumann, "Novel three-phase AC-DC-AC sparse matrix converter," in Proceedings of the 17th IEEE Applied Power Electronics Conference and Exposition, 2002, pp 777-790.
- [10] C.Klumpner, P.Nielsen, F.Blaabjerg, "Speeding- up maturation process of the matrix converter," in Proceedings of the 32nd IEEE PESC, 2001, Canada, vol.2, pp.1083-1088.
- [11] B.Ozpineci and L.M.Tolbert, "Simulink implementation of induction machine model," IEEE 0-7803-7817-2/03/, 2003, pp. 728 - 733.
- [12] Klumpner C, Nielson P, Boldea I, Blaabjerg F (2002) A new matrix converter motor (MCM) for industry application. Proc IEEE Trans Ind electron 49:325-335
- [13] Krasuse PC, Thomas CH (1965) simulation of symmetrical induction machinery. Proc IEEE Trans power apparatus syst 84:1038-1053