

Controlling of Smart City Equipment using Smart Phones

Mukesh Choudhary¹ Shalini Jain² Aashiq Hussain³ Hemant Sahu⁴

^{1,2,3}Assistant Professor ⁴Associate Professor & Head of Department

^{1,2}GITS, Dabok, Udaipur, RAJ. ³CPU University KOTA ⁴GITS, Dabok, Udaipur, RAJ

Abstract— Nowadays, people carry smart phones with them all the time. So it makes sense to use this smart phone to control the home appliances. This paper presented here is a home automation system using a simple Android app, which you can use to control electrical home appliances with one touch or voice commands. Commands are sent via Bluetooth to Arduino Uno. Arduino Uno sends the commands to the relays. Relays are operates the desired devices. So you need not get up to switch ON or switch OFF the device while watching a movie or doing some work or outside of your home.

Key words: smart phone, microcontroller, voice command

I. INTRODUCTION

Infrastructure of a city consists of inter alia, housing, sanitation, water supply and sewage, electric power supply and distribution, transportation, waste management and communication between different segment. Smart city infrastructure differentiates itself from the traditional urban infrastructure in many ways through its ability to respond smartly to changes in its environment and the workplace around us, including user requirements and other infrastructure like clean water, renewable energy, smart power cuts etc. , to achieve an improved performance and better response from everywhere [1]. Smart City is a need of today's era and it provides base to all the six important key themes related to a smart city namely, smart mobility, smart economy, smart living, smart governance, smart people as well as smart environment. But the smart infrastructure components are highly context specific and their nature is determined by the level of development of the cities as well as by the required challenges in the field of demands. [2]

For a city in a developing country, the immediate need is to provide adequate urban infrastructure and to all the facilities and luxurious requirement to meet the increasing pace of urbanization and to cope with the today's demand of common citizen. Therefore, in the process of meeting these infrastructure demands, smart infrastructure applications provide an avenue for these cities to leapfrog, as shown by a recent study on Africa and smart cities which can prove to be the best example in the field of demand and fulfilment of demand with respect to the smart city requirement. Further, these smart infrastructure requirements have the potential to provide foundations for new innovations and discoveries that will promote efficiency, and will promote better overall development of cities, and there is a better management of resources.[3] For example, the data generated by new smart mobility infrastructure could provide useful information for redesigning transport networks as well as to build new smart mobility apps for smart phones and it's easily handled by every normal citizen. "A smart sustainable city (SSC) is an innovative and developed city that uses information and communication technologies (ICTs) like smart phone and other means to improve quality of life and increase the enhancement of life mobility, efficiency of urban operation and services, and competitiveness, while ensuring that it meets the needs of present and future generations with respect to economic, social and environmental aspects and in sometime will able to meet the demand of common people and will lead to a fully developed country".[6]

II. KEY PARAMETERS OF SMART CITY

Following parameters are required for smart city developments

A. Smart Mobility

- Improved Accessibility by common people
- Safe Transportation for all
- More efficient and intelligent transportation systems
- New 'social' attitudes such as car sharing, car-pooling, and car-bike combinations.
- There will be direct link between urban and rural areas.

B. SMART ECONOMY

- Regional/global competitiveness required
- Entrepreneurship & Innovation Momentum
- High Levels of Productivity in all direction
- Business opportunities required for every class
- Independent of location, helping maintain population in rural areas,
- Develop Electronic business processes (e.g., e-banking, e-shopping, e-auction)

C. SMART LIVING

- Better Quality of Life for all class
- Social Aspects - Education, healthcare, Public Safety, Housing
- Access to high-quality healthcare services (including e-health or remote healthcare monitoring), electronic health records management
- Home automation, smart home and smart building services green building
- Access to social services of all kinds of people.

D. SMART GOVERNANCE

- Participatory Decision Making
- Public & Social Services available on online
- Transparency required
- Democratic processes and inclusion
- Interconnecting governmental organizations and administrations for all people.
- Improving community access to services in all part of city.

E. Smart People

- Everybody must be Social & Human
- Qualified, Creative and Educated Citizen required
- Able to utilize the ICT based smart services etc
- Delivering a more consistent educational experience in both urban and rural areas

F. Smart Environment

- Pollution Monitoring must be there
- Use of Sustainable Technologies
- Environmental/ sustainable /Energy consumption
- Reducing energy consumption through novel technology innovations while promoting energy conservation and material re-use

G. Smart Technology

- Smart LED lighting systems
- Smart display
- Internet of Things (IoT)
- Reducing energy consumption through novel technology
- Controlling of Electronic Devices through smart phone
- Smart traffic light monitoring

III. CONTROLLING OF EQUIPMENTS THROUGH SMART PHONE

Now a day's smart phone are very essential part of our life. Without smart phone we feel ourselves as physically handicapped. Mobile phones have really changed the way of communications. Cell phones are the most used communication tool today life. They are not limited to communication purposes but they are playing various roles in our daily life. The small electronics gadget is a basic necessity of life. But why its tagged by everybody that mobile phones as basic necessity of life?.In the hustle and bustle of modern life, there are so many important elements. You might find yourself with a busy and hectic schedule. There are certain elements of your life that you will need to sort out and organise. It is important that to you have a schedule and to plan the things to make your life run smoother.

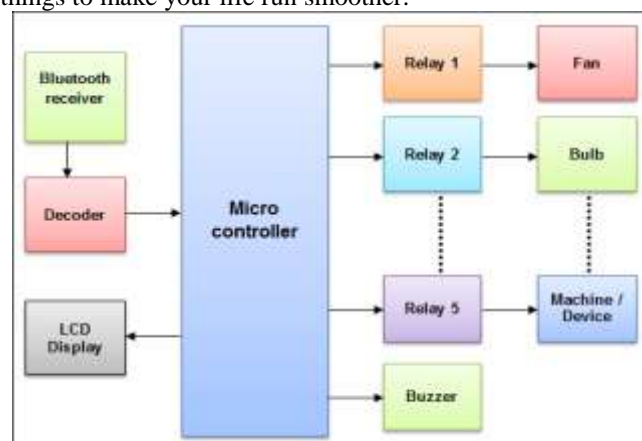

Fig. 1: controlling layout [5]

These days on of the most important devices you can use to help with your life is a smart phone. There is so many things can do with a smart phone and so many different ways in which they play a key role in your life. If you don't yet have a smart phone, kindly get one.

If you want to enhance and advance your working life and personal life, then you will required to get a smart phone with good internet connectivity.. You can use your smart phone like a miniature laptop. This means that you can live so much of your day to day lifestyle on the move. Smart phone is essential part of today life.

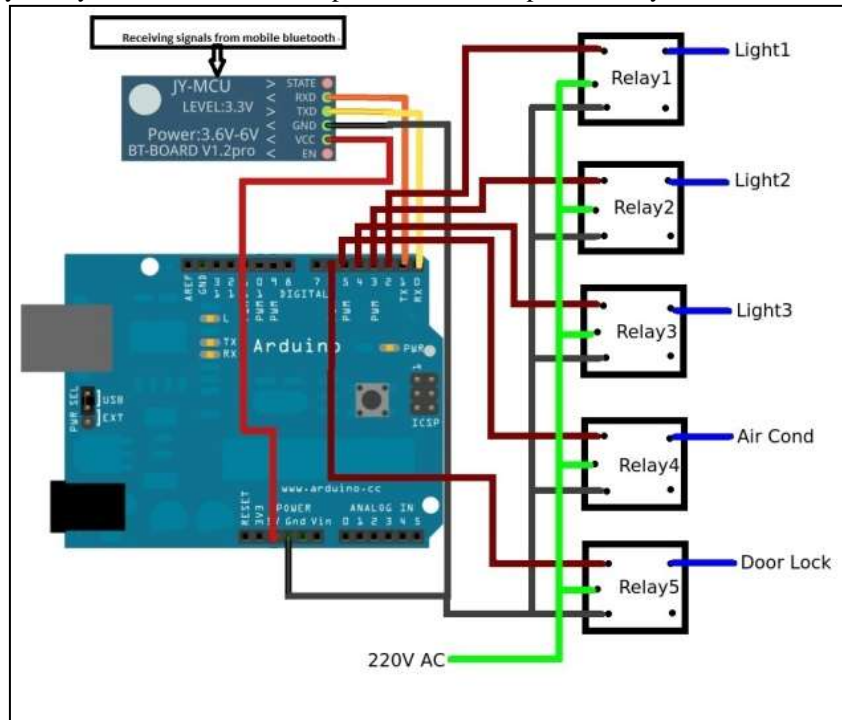

Fig. 2: Microcontroller with relay [8]

IV. WORKING PRINCIPAL

The heart of this system is microcontrollers. There are many microcontrollers that can be used for this purpose. But aurdino microcontroller is easy to implement. Arduino is an open-source electronics platform based on easy-to-use hardware and software. Arduino boards are able to read inputs - light on a sensor, a finger on a button, - and turn it into an output - activating a motor, turning on an LED. You can tell your board what to do by sending a set of instructions to the microcontroller on the board. [7]

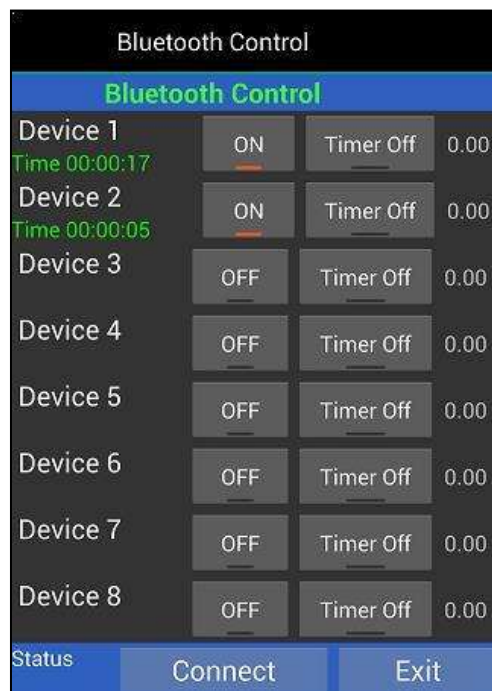

Fig. 3: Equipment control pad [5]

LED signal control the relay. The control circuit functions as the coupling between the input and output circuits. In electromechanical relays, this function accomplishes by coil. Output of relays circuit is the portion of the relay that switches on the load and performs the same function as the mechanical contacts of electromechanical relays.[9]

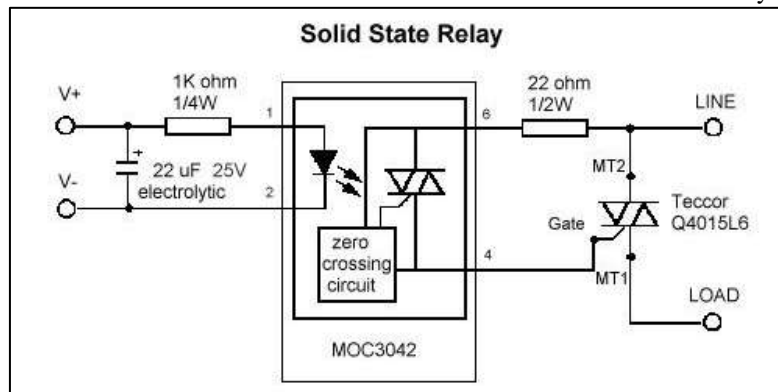

Fig. 4: Internal Diagram of Relay [9]

V. CONCLUSION

As we are making city smart there are many kind of work which can be done by just sitting at one place by the use of mobile phone. We can control the process system of house. We can switch on or off the appliances by remote location. This help in saving of energy also avoid any type of accidents. The wireless control system such as radio frequency based systems, infrared remote based systems has limitation. A mobile phone based control system can overcome this drawback; it also provides some advantages like no interference with other electronic gadgets. These make one steps ahead towards smart city developments

REFERENCES

- [1] Advance Electronic Project for your home And Automobile, Second. PROMPT Publication, 1998, pp. 67– 70
- [2] S. K. Subramaniam, S. H. Husin, S. A. Anas, and A. H. Hamidon, “Multiple Method Switching System for Electrical Appliances using Programmable Logic Controller,” vol. 4, no. 6, pp. 243–252, 2009.
- [3] Dr. K N Sheth, “Clean Environmental Issues of Smart Cities”, presented at GTU on Seminar on Smart Cities – Quo Vadis?, Organized by center for governance system- GTU, Ahmedabad (Aug, 2014) https://www.researchgate.net/publication/316630559_Clean_Environmental_Issues_of_Smart_Cities
- [4] M. Sikandar, H. Khiyal, A. Khan, and E. Shehzadi, “SMS Based Wireless Home Appliance Control System (HACS) for Automating Appliances and Security Preliminaries Home Appliance Control System (HACS),” Issue s In Science and Information Technology, vol. 6, pp. 887–894, 2009
- [5] Sougata Das, Nilava Debabhuti, Rishabh Das, Sayantan Dutta and Apurba Ghosh, “Embedded System for Home Automation Using SMS” IEEE International Conference on Automation, Control, Energy and Systems (ACES), pp. 1-6, Feb 2014
- [6] Manish Kumar and Ramandeep Singh, “HOME APPLIANCE CONTROLLING USING ZIGBEE ON ATMEGA128 HARDWARE PLATFORM”, International Journal of Research in Engineering and Technology, Volume: 03 Issue: 07, pp. 469-472, Jul-2014.
- [7] "The arduino source code". The Arduino source code.1
- [8] "Using Atmel Studio for Arduino development". Megunolink.com. Retrieved 2013-01-18.
- [9] US Patent 1,647, Improvement in the mode of communicating information by signals by the application of electro-magnetism, June 20, 1840